

TOILET TISSUE DISPENSER

- Jumbo Roll **Bradex™**
- Surface Mounted

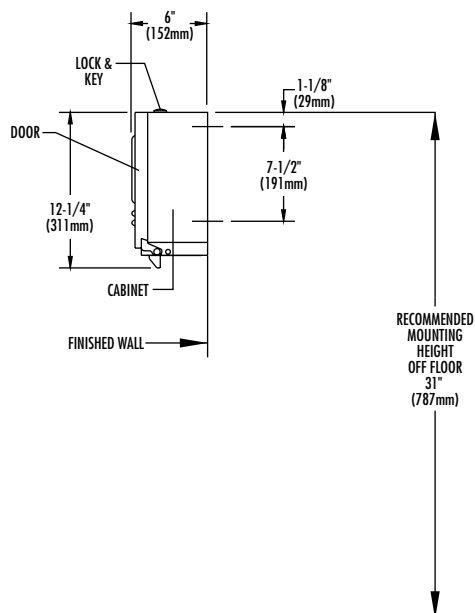
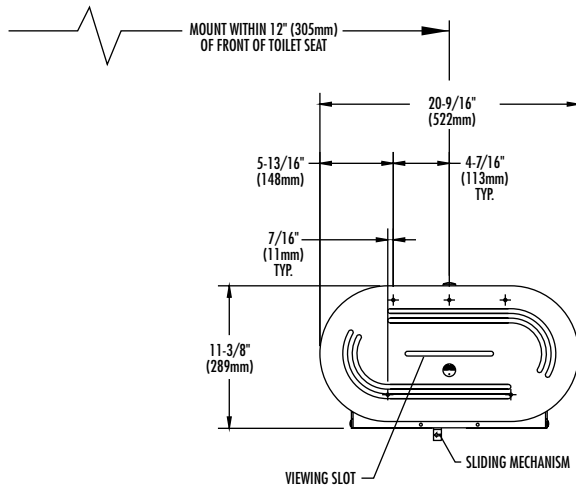

CONSTRUCTION:

- **CABINET & MOUNTING PLATE** fabricated of 18-gauge type 304 satin finish stainless steel.
- **DOOR** fabricated of 18-gauge, type 304 satin finish stainless steel. Drawn one-piece construction. Furnished with tumbler lock and refill-indicator viewing slots.
- **DISPENSING MECHANISM** fabricated of chemical and flame retardant ABS.

OPERATION:

Cabinet holds two 9" diameter rolls of 3" or 2-1/4" diameter core toilet tissue (by using core adapters). When first roll is depleted, the bottom access panel level is slid to the other side, revealing the second roll. Refill indicator slot reveals tissue level. Tumbler-locked door swings down to replenish tissue rolls.

INSTALLATION:

Secure unit to wall or toilet partition with five screws (included) through mounting holes. For barrier-free installation, mount unit so that centerline of tissue rolls is 19" min. to 44" max. above the finished floor, and the front edge of the unit is within 36" of the back wall.

GUIDE SPECIFICATION:

Jumbo roll toilet tissue dispenser shall be 18 gauge satin finish stainless steel. Dispensing mechanism shall be flame and chemical retardant ABS plastic. Unit shall dispense two 9" diameter toilet tissue rolls with 3" or 2-1/4" diameter core. Unit shall have a sliding access panel to allow dispensing from one roll at a time. Door shall be secured with a tumbler lock and shall have a refill indicator viewing slot.

Document No. 8556

This information is subject to change without formal notice.
© 2005 Bradley Corporation
2-11-2005

Orders composed of products indicated as **Bradex™** will be available to ship in one week after receipt of order at the factory. There is no pricing penalty for this service from Bradley.



P.O. Box 309, Menomonee Falls, WI 53052-0309
Phone 1-800-BRADLEY FAX 262-253-4161
Web Site: <http://www.bradleycorp.com>