

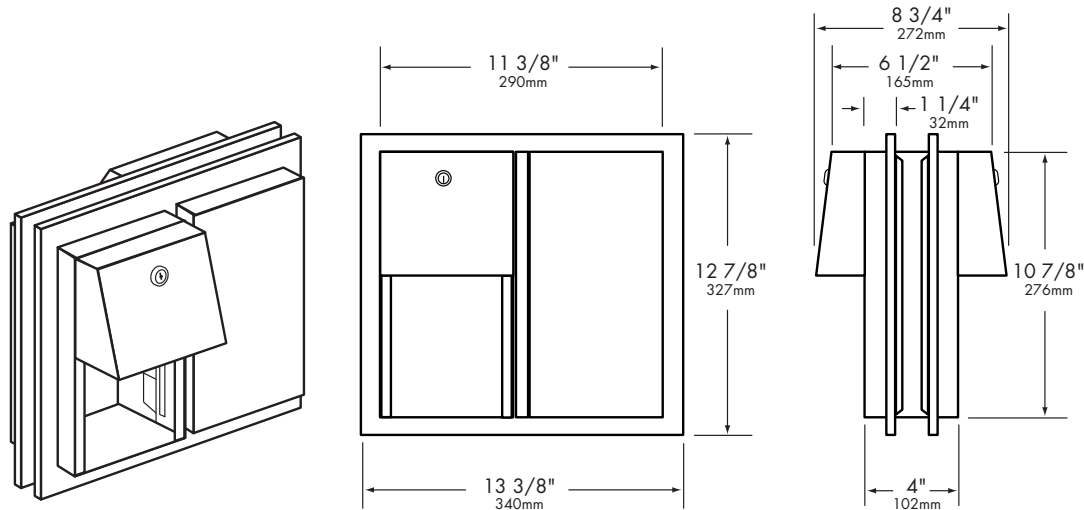

TTD-7 Multi-Roll Toilet Tissue Dispenser



Construction:

Cabinet - fabricated of 18" (1.2mm) and 22 gauge (0.8mm), 18-8 type 304 stainless steel with exposed surfaces #4 satin finished. All welded construction.

Door - fabricated of 18 gauge (1.2mm) 18-8 type 304 stainless steel with exposed surfaces #4 satin finished. Door attached with heavy duty rivets and is fitted with tumbler lock

Flange: fabricated of 22 gauge (0.8mm), 18-8 type 304 stainless steel with #4 satin finish with 90° return for extra rigidity, one piece seamless flange.

Dispensing Mechanism and Inner Cabinet - fabricated of 18 gauge (1.2mm) and 22 gauge (0.8mm), 18-8 type 304 stainless steel.

Spindles - one piece molded ABS polyethylene with stainless steel tips to prevent damage when roll automatically drops in place. Roller can not be removed when door is locked.

Toilet tissue rolls are loaded and locked into dispensing mechanism. Extra roll automatically drops in place after bottom roll is depleted. Depleted rolls can only be removed after unlocking door. Serves two compartments with ease of loading from both sides.

Capacity:

Two rolls up to 5-1/4" (135 mm) diameter, 1800 sheets, each side

Overall Dimensions:

13-3/8"W x 12-7/8"H x 8-3/4"D
340mm x 327mm x 222mm

Wall Opening:

11-3/4"W x 11-1/4"H
298mm x 286mm

Mounting:

28" (711mm) to 37" (940mm) to top of unit, mount center through toilet partition. Two flanges provided for partition mounting 1/2" (13mm) to 2" (51mm) thickness serving two compartments.

ADA Guide:

ADA mounting guide: toilet tissue rolls should be mounted with forward edge no more than 36" (914mm) from the back wall of stall. All toilet tissue dispensers should be mounted with their horizontal centerline at least 19" (483mm) above the finished floor.

Options:

TTD-5 surface mounting units available
TTD-6 wall recessed unit available

Manufacturer reserves the right to make changes in design or dimensions without formal notice.