

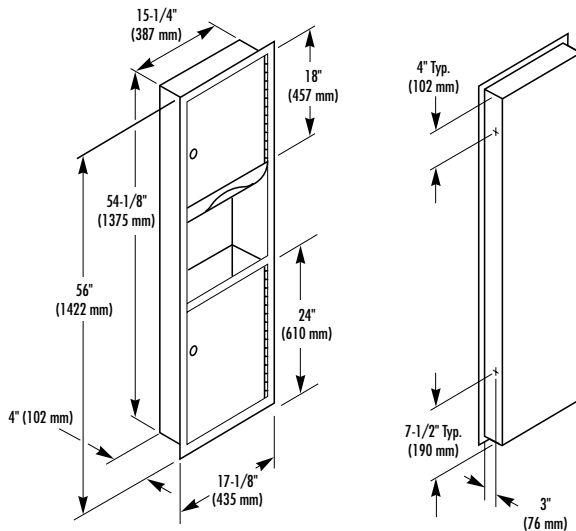

This unit meets "Barrier Free" requirements when mounted in accordance with local ordinances.

TOWEL DISPENSER/ WASTE RECEPTACLE

- Model 235 – Recessed **Bradlex**[®]
- Model 235-10 – Semi-recessed (recesses 2"; projects 2")
- Model 235-11 – Surface-Mounted (projects 4")



Orders composed of products indicated as **Bradlex**[®] will be available to ship in one week after receipt of order at the factory. There is no pricing penalty for this service from Bradley.

Document No. 8135

This information is subject to change without formal notice.
© 2007 Bradley Corporation
3-27-2007

CONSTRUCTION:

- **FLANGE** fabricated of type 304 (18-8), 22 gauge stainless steel with exposed surfaces in architectural satin finish. One piece seamless construction, 1" wide with 1/4" return.
- **CABINET** fabricated of type 304 (18-8), 22 gauge stainless steel with exposed surfaces in architectural satin finish. Welded construction with seamless corners and burr-free edges.
- **DOORS** fabricated of type 304 (18-8), 18 gauge stainless steel. Warp resistant, with full length piano hinge and tumbler lock keyed like other Bradley units.
- **TOWEL DISPENSER** fabricated of type 304 (18-8), 22 gauge stainless steel. Rolled edge on dispenser opening.
- **WASTE RECEPTACLE INSERT** fabricated of leakproof molded plastic.
- **CUP DISPENSER** (optional) fabricated of type 304 (18-8), 22 gauge stainless steel.

CAPACITY:

Towel Dispenser - 800 multi-fold or 500 C-fold paper towels; Waste Receptacle Insert - 4.9 gal. (.65 cu. ft.); Cup Dispenser (optional) - 100-3 oz. cups.

OPERATION:

Towel dispenser holds multi-fold or C-fold towels without use of special adaptor. Waste receptacle insert removable for easy servicing by unlocking cabinet door.

INSTALLATION:

Recessed unit requires rough wall opening 15-3/4"W x 54-5/8"H x 4"D (Semi-recessed unit only 2" deep). Top of wall opening 5'-2" min. to 6'-6" max. above finished floor. Secure to framing with mounting screws (included) at holes provided. Shim at screw points as required.

OPTIONAL FEATURES

Feature	Suffix
<input type="checkbox"/> Mirror	-19
<input type="checkbox"/> Cup dispenser	-27
<input type="checkbox"/> Self-closing push-flap door	-35

GUIDE SPECIFICATION:

Recessed combination towel dispenser and waste receptacle shall be fabricated of type 304 (18-8), 22 gauge stainless steel with exposed surfaces in satin finish. Cabinet doors of warp-free construction, equipped with full length piano hinge and secured by tumbler lock. Towel dispenser capacity 800 multi-fold or 500 C-fold towels. Removable 4.9 gal. leakproof molded plastic insert for waste receptacle.

Overall dimensions: 17-1/8"W x 56"H x 4"D.

Recessed Combination Towel Dispenser and Waste Receptacle shall be Bradley Model 235.



P.O. Box 309, Menomonee Falls, WI 53052-0309
Phone 1-800-BRADLEY FAX 262-253-4161
Web Site: <http://www.bradleycorp.com>