

**U363
 FLIP TOP ASHTRAY**

JOB #:

ITEM #:

QTY:

MOUNTING HANDING TYPE SIZE OTHER

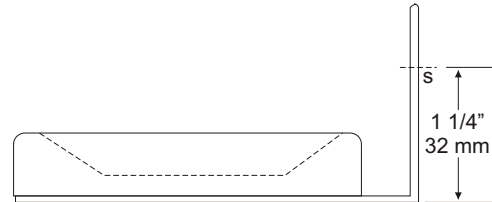
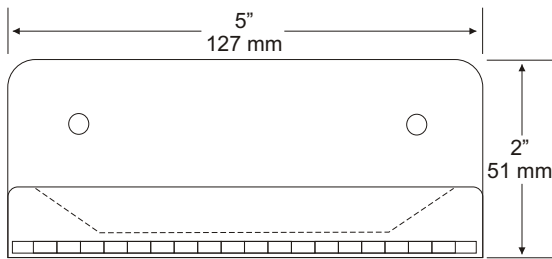
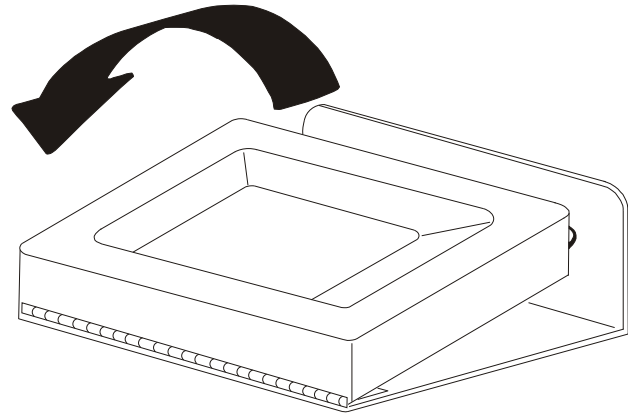
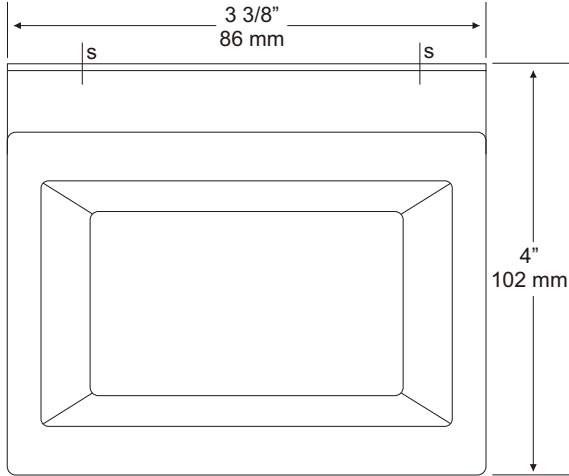

SPECIFICATIONS:

Flip Top: Fabricated of type 304 #18 gauge stamped stainless steel with a #4 satin finish.

Mounting Bracket: fabricated of type 304 #18 gauge stainless steel finished to match flip top.

Hinge: Full length heavy duty stainless steel piano type hinge secures bracket to flip top. Bracket is equipped with exposed mounting points.

Overall Size: 5"W x 2"H x 4"D
 127mm x 51mm x 102mm

INSTALLATION:

Place unit on mounting surface making sure unit is level. Transfer mounting points and drill pilot holes. Secure ash tray to surface with proper fasteners per application. When properly mounted, the flip top should raise up with ease to have the ashes dumped into waste receptacle for ashes.

APPLICATION:

To provide a surface mounted ash receptacle.



Form: U363/2000